



# TECHNICAL DATASHEET

LEAD - AGMSTARTER BATTERY

BATTERY TYPE AGM	<b>12V 95Ah</b>	<b>PS95.0AGM</b>
CATALOGUE NUMBER		

GENERAL PROPERTIES	
Case Type	LB5
Voltage (V)	12 V
Capacity C20	95 Ah
Cold cranking current -18°	850A -(EN)
Charge condition	Wet
Technology	AGM
Weight	23,Kg (+/-1.5%)

TECHNICAL PROPERTIES	L x A x AL
Overall dimensions	353 x 175 x 190mm
Case material	Polypropylene
Lid material	Polypropylene
Case colour	Black
Lid colour	Black
Degassing system	Central
Charge indicator	NO
Terminal type	1 (DIN)
Terminal layout	0
Base hold down	B13

(+ ) PLATE	
Grid casting technology	Expanded grid
Alloy type	Pb - Ca

(-) PLATE	
Grid casting technology	Expanded grid
Alloy type	Pb - Ca

SEPARATOR	
Type	Envelope
Material	Polyethylene HP

ELECTROLYTE	
Electrolyte	1.270 (+/-0.01g/cm <sup>3</sup> )

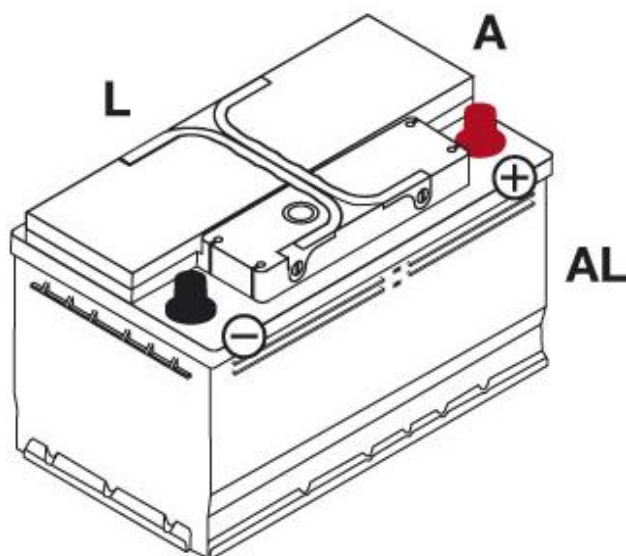

**NORMA DURACION DE VIDA CEI - EN - 50342-1**

Fabricado en C.E. según las normas ISO 9001 – ISO 14001 e I.P.P.C.